

SUBMITTAL DATA SHEET

NL Service Fitting – 73202

FNPT x XS Lead Union

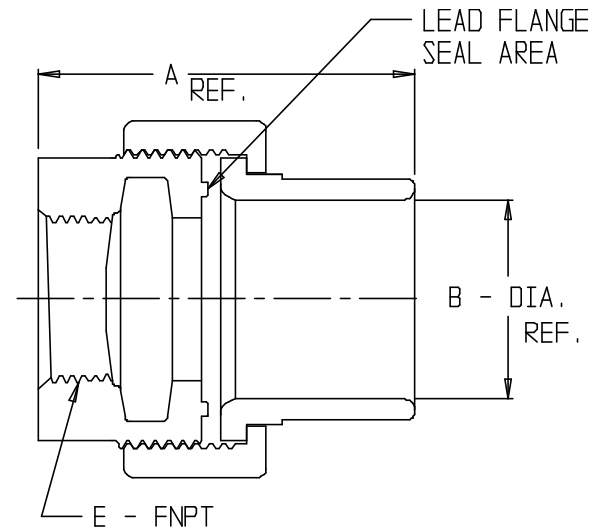
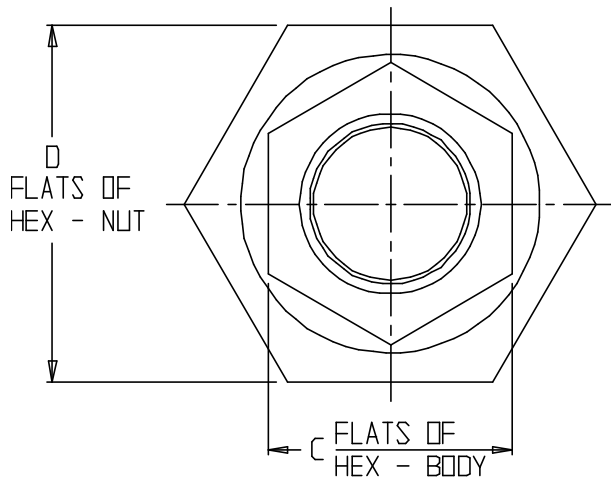

MODEL	SIZE	A	B	C	D	E
73202	1/2	2.05	.96	1.13	1.81	1/2
73202	5/8	2.18	1.10	1.44	1.81	3/4
73202	3/4	2.25	1.23	1.50	2.19	3/4
73202	1	2.38	1.51	1.66	2.44	1

SUBMITTAL INFORMATION

- Manufactured in compliance with ANSI/AWWA C800 (latest revision)
- Brass components in contact with potable water conform to ASTM B584, UNS C89833 (latest revision) and identified with “NL”
- Certified to NSF/ANSI 61 and NSF/ANSI 372
- Brass components not in contact with potable water conform to ASTM B62 and ASTM B584, UNS C83600 -85-5-5-5 (latest revision)
- Large wrench flats provided for proper installation



A.Y. McDonald Mfg. Co.
4800 Chavenelle Rd
Dubuque, IA 52002

Toll Free: 1-800-292-2737
sales@aymcdonald.com
aymcdonald.com

A.Y. McDonald considers the information on this assembly drawing correct when published. Item and option availability, including specifications, are subject to change without notice.

Submitted by: