

SUBMITTAL DATA SHEET

Irrigation & Superbooster Pumps
Superbooster | Centrifugal

1500XSW Series | Multi-Stage Centrifugal Pumps



This two stage construction multi-stage centrifugal pump provides pressure to 60 PSI for high pressure applications. Motors are Nema standard construction, coupled shaft design and available in both single and three-phase. Housing and adapter are cast iron. Impeller of your choice - no-lead bronze or plastic.

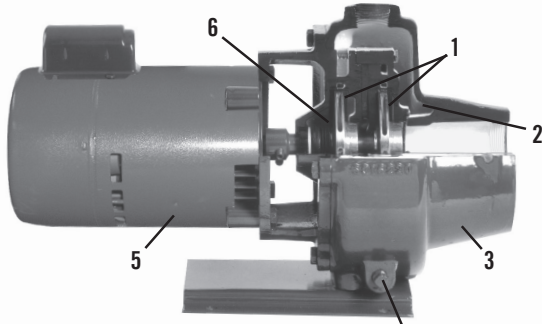

- 1 - **Impeller**
Available in either dynamically balanced no-lead bronze or engineered thermoplastic
- 2 - **Cast Iron Diffusers**
Precision machined for greatest efficiency
- 3 - **Cast Iron Pump Body & Motor Adapter**
- 4 - **Drain Plug**
- 5 - **Nema Standard Motor**
Heavy duty, capacitor start, dual voltage (230/115) with built-in overload protection. Choice of 3/4, 1, 1 1/2, & 2 HP. 60 Hz.
- 6 - **Shaft Seal**
Standard 3/4" ceramic carbon rotating mechanical seal

Performance

Model No.	HP	Suction Lift - FT.	Capacities in GPM at Discharge Pressure				
			20	30	40	50	60
1575XSW 1575XSW3	3/4	10	34.3	28.8	22.2		
		15	33.2	27.6	20.4		
		20	32	26	18.4		
		25	29.9	24.9	--		
1510XSW 1510XSW3	1	10	41.7	37.7	31.7	24.2	
		15	40	36.5	30.2	22.2	
		20	36.6	34.3	28.5	19.8	
		25	29.5	28.5	26.5	16.5	
1515XSW 1515XSW3	1 1/2	10	42.3	40.5	36.5	32	24.5
		15	41.7	39.8	35.3	29.3	23
		20	40.3	39	34	28	21
		25	33.3	32.5	31	26.5	18.8

- To order with **plastic impeller**, add "P" to model number above. **Example: 1575XSWP**

Specifications

Part No.	Model No.	HP	Voltage	Phase	Suction	Discharge	Stages	Ship WT. (lbs.)
6331-100	1575XSW	3/4	115 / 230	1	1 1/4"	1"	2	64
	1575XSW3	3/4	230 / 460	3	1 1/4"	1"	2	59
6326-100	1510XSW	1	115 / 230	1	1 1/4"	1"	2	64
6326-102	1510XSW3	1	230 / 460	3	1 1/4"	1"	2	61
6327-100	1515XSW	1 1/2	115 / 230	1	1 1/4"	1"	2	66
6327-102	1515XSW3	1 1/2	230 / 460	3	1 1/4"	1"	2	64

SUBMITTAL INFORMATION

- Trouble-free (carbon-ceramic) seal.

NO-LEAD: The weighted average of the wetted surface of this no-lead product contacted by consumable water contains less than one quarter of one percent (0.25%) lead.



A.Y. McDonald Mfg. Co.
4800 Chavenelle Rd
Dubuque, IA 52002

Toll Free: 1-800-292-2737
sales@aymcdonald.com
aymcdonald.com

A.Y. McDonald considers the information on this assembly drawing correct when published. Item and option availability, including specifications, are subject to change without notice.

Submitted by: