

SUBMITTAL DATA SHEET

Stainless Steel Saddle – 78423

4" - 12" All Taps

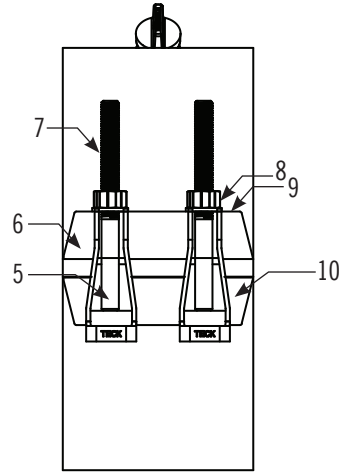
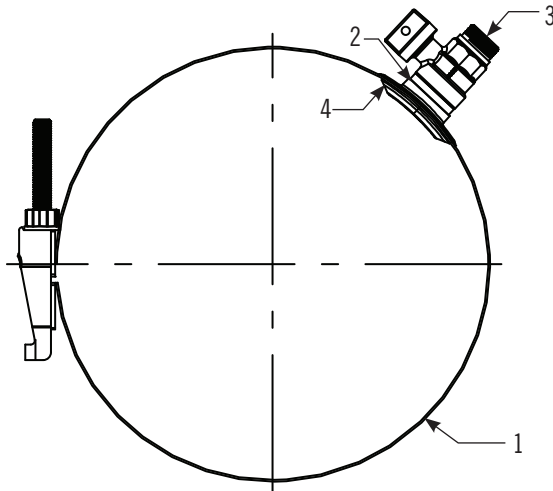
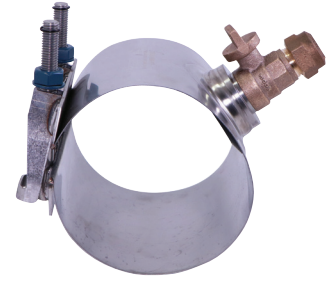

Parts & Materials

- | | |
|---|---|
| <p>1. Saddle body made of 18-8 type 304 Stainless Steel</p> <p>Size 4" - 20 gauge</p> <p>Size 6" - 8" - 20 gauge (3/4" to 1" outlets)</p> <p>- 18 gauge (1 1/4" to 2" outlets)</p> <p>Size 10" & 12" - 18 gauge</p>
<p>Size 4" - 12"</p> <p>- 6" width (3/4" to 1" outlets)</p> <p>- 8" width (1 1/4" to 2" outlets)</p> | <p>2. Welded taps made of 18-8 type 304 Stainless Steel</p> <p>3. No-Lead Brass Ball Valve Compliant with NSF 61 & NSF 372</p> <p>4. Saddle Gasket is made of EPDM & Meets Standards ASTM D2000 & NSF 61</p> <p>5. Teck™ Fingers made of 18-8 type 304 Stainless Steel</p> <p>6. Finger Bracket made of 18-8 type 304 Stainless Steel</p> <p>7. Studs made of 18-8 type Stainless Steel 5/8" Roll NC Thread</p> <p>8. 5/8-11 Stainless Steel Heavy Hex, coated nuts to prevent galling</p> <p>9. Washers made of 18-8 type 304 Stainless Steel</p> <p>10. Side bars made of 18-8 type 304 Stainless Steel</p> |
|---|---|

SUBMITTAL INFORMATION

- | | |
|--|--|
| <ul style="list-style-type: none"> - All saddle components are made of 18-8 type Stainless Steel - Fully passivated for corrosion resistance - Teck™ Finger design - no loose parts for assembly - Saddle size is clearly marked on the side of each saddle - EPDM is standard rubber material, NBR is available upon request - Ring gasket and pad gasket options are available upon request - Recommended saddle bolt torque ~ 60 ft/lbs - Blowout proof stem design | <ul style="list-style-type: none"> - All brass valve components conform to AWWA standard C800 (ASTM B-584 UNS NO C89833 for all brass parts in contact with potable water, and ASTM B-62 and ASTM B-584 UNS NO C83600 for all other brass parts) - Conforms to ANSI/NSF 372 (Compliant with US Safe Drinking Water Act. PL 111-380) - Conforms to ANSI/NSF Standard 61-8 - Encapsulated lugs under cap provide 90 degree open to close operation - Rated for 250 PSI working pressure |
|--|--|



A.Y. McDonald Mfg. Co.
P.O. Box 508
Dubuque, IA 52004-0508

Toll Free: 1-800-292-2737
Fax: 1-800-832-9296
Hours: 7:00 a.m. - 5:00 p.m., CST

sales@aymcdonald.com
www.aymcdonald.com

A.Y. McDonald considers the information on this assembly drawing correct when published. Item and option availability, including specifications, are subject to change without notice.

Submitted by: