

SUBMITTAL DATA SHEET

Gas Meter Bars – 6644-C-- 1 1/4 X 1 1/4 X 1 1/4

FNPT x FNPT

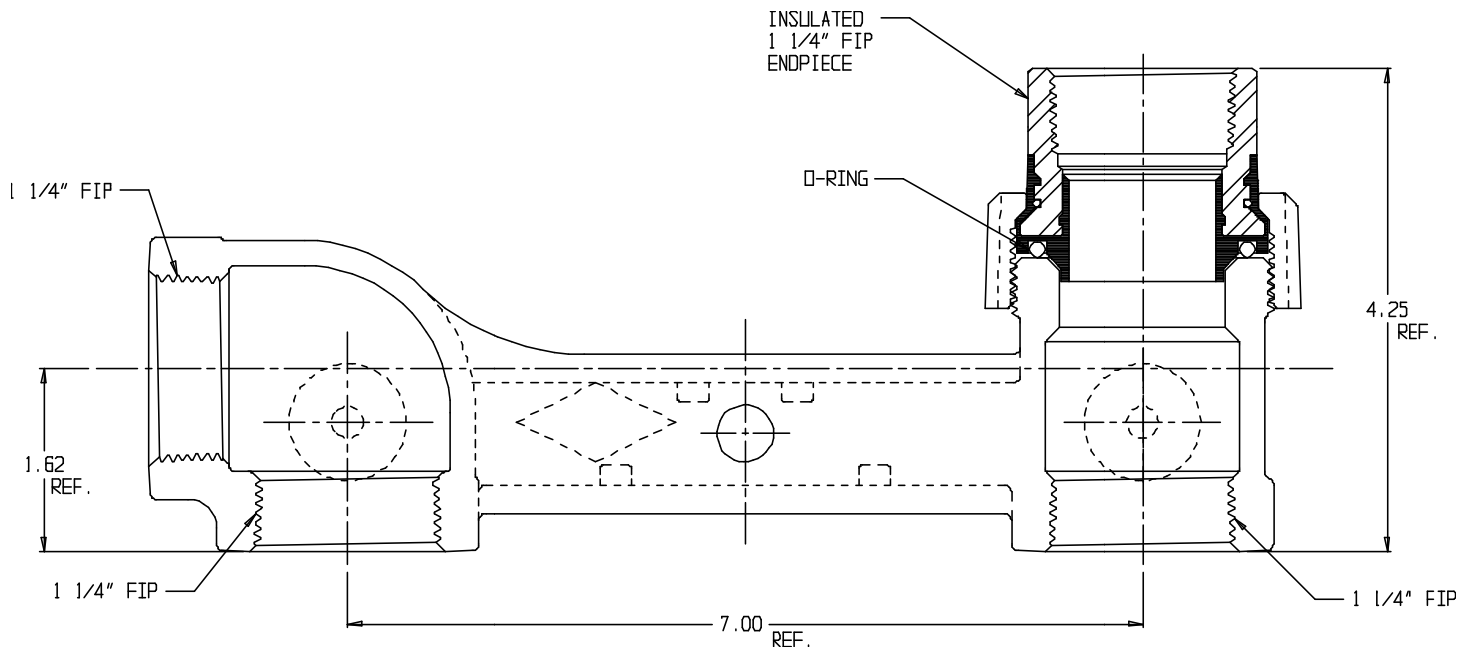

SUBMITTAL INFORMATION

- Iron castings conform to ASTM A126 Class B Iron, with optional zinc coating per ASTM B633 with clear chromate coating and silicate sealer (latest revisions)
- Pipe threads manufactured in compliance with ASME/ANSI B1.20.1 (latest revision)
- Pressure test taps available in multiple positions and sizes
- Rated for 2 PSIG natural, manufactured, or LP gas pressure



A.Y. McDonald Mfg. Co.
P.O. Box 508
Dubuque, IA 52004-508

Toll Free: 1-800-292-2737
Fax: 1-800-832-9296
Hours: 7:00 a.m. – 5:00 p.m., CST

sales@aymcdonald.com
www.aymcdonald.com

A.Y. McDonald considers the information on this assembly drawing correct when published. Item and option availability, including specifications, are subject to change without notice.

Submitted by: