

SUBMITTAL DATA SHEET

Swing Connect Hinged Saddle - 3894

IPS PVC x FNPT

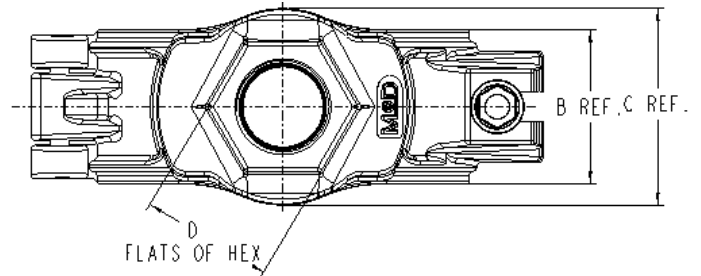

MODEL	SIZE	A	B	C	D	E
3894	4X3/4	3/4	2.00	2.56	1.69	4.500
3894	4X1	1	2.00	2.56	1.69	4.500
3894	6X3/4	3/4	2.00	2.56	1.69	6.625
3894	6X1	1	2.00	2.56	1.69	6.625
3894	8X3/4	3/4	2.00	2.56	1.69	8.625
3894	8X1	1	2.00	2.56	1.69	8.625

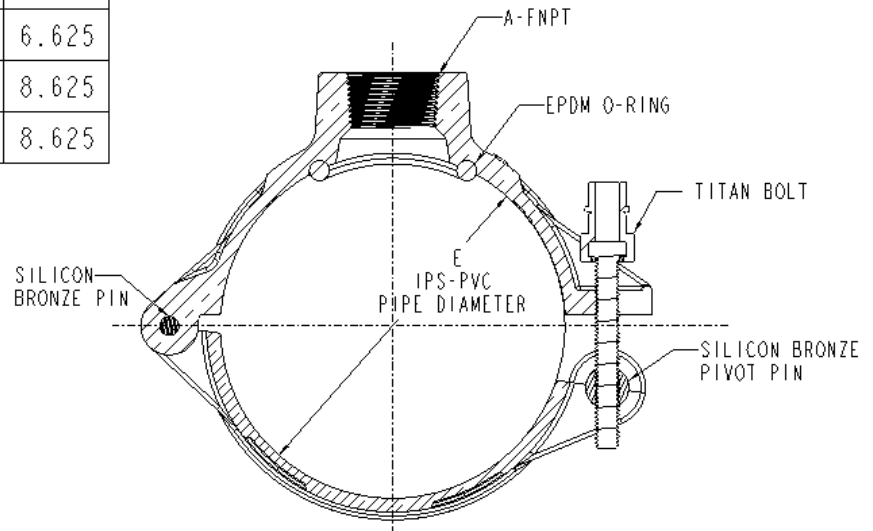

SUBMITTAL INFORMATION

- Manufactured in compliance with ANSI/AWWA C800 (latest revision)
- Brass components conform to ASTM B62 and ASTM B584, UNS C83600 -85-5-5-5 (latest revision)
- Certified to NSF/ANSI 61
- Silicon Bronze hinge pin and bolt(s)
- EPDM o-ring
- Pipe and tap size, and thread type identified on saddle
- Outlet boss with large wrench flats



A.Y. McDonald Mfg. CO.
4800 Chavenelle Rd
Dubuque, IA 52002

Toll Free: 1-800-292-2737
sales@aymcdonald.com
aymcdonald.com

A.Y. McDonald considers the information on this assembly drawing correct when published. Item and option availability, including specifications, are subject to change without notice.

Submitted by: