

SUBMITTAL DATA SHEET

Hinged Saddle – 3895SB

C900 PVC x AWWA/CC



MODEL	SIZE	A	B	C	D	E	F	G
3895	4 X 1/2	1/2	2.00	2.56	1.69	HEX	4.800	1
3895	4 X 3/4	3/4	2.00	2.56	1.69	HEX	4.800	1
3895	4 X 1	1	2.00	2.56	1.69	HEX	4.800	1
3895	4 X 1 1/2	1 1/2	2.50	3.96	3.10	OCT	4.800	2
3895	4 X 2	2	2.50	3.96	3.10	OCT	4.800	2
3895	6 X 1/2	1/2	2.00	2.56	1.69	HEX	6.900	1
3895	6 X 3/4	3/4	2.00	2.56	1.69	HEX	6.900	1
3895	6 X 1	1	2.00	2.56	1.69	HEX	6.900	1
3895	6 X 1 1/2	1 1/2	2.50	3.96	3.10	OCT	6.900	2
3895	6 X 2	2	2.50	3.96	3.10	OCT	6.900	2
3895	8 X 1/2	1/2	2.00	2.56	1.69	HEX	9.050	1
3895	8 X 3/4	3/4	2.00	2.56	1.69	HEX	9.050	1
3895	8 X 1	1	2.00	2.56	1.69	HEX	9.050	1
3895	8 X 1 1/2	1 1/2	2.50	3.96	3.10	OCT	9.050	2
3895	8 X 2	2	2.50	3.96	3.10	OCT	9.050	2

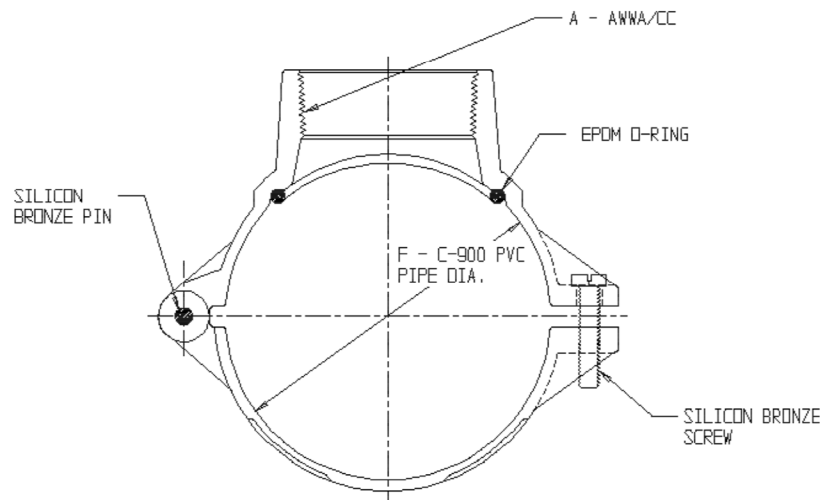
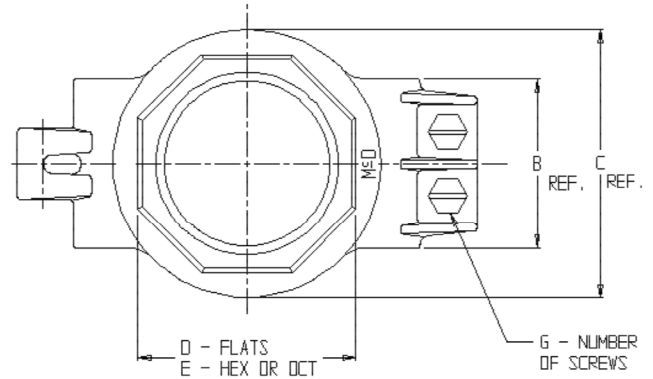

SUBMITTAL INFORMATION

- Manufactured in compliance with ANSI/AWWA C800 (latest revision)
- Brass components conform to ASTM B62 and ASTM B584, UNS C83600 -85-5-5-5 (latest revision)
- Certified to NSF/ANSI 61
- Silicon Bronze hinge pin and bolt(s)
- EPDM o-ring
- Pipe and tap size, and thread type identified on saddle
- Outlet boss with large wrench flats



A.Y. McDonald Mfg. CO.
4800 Chavenelle Rd
Dubuque, IA 52002

Toll Free: 1-800-292-2737
sales@aymcdonald.com
aymcdonald.com

A.Y. McDonald considers the information on this assembly drawing correct when published. Item and option availability, including specifications, are subject to change without notice.

Submitted by: