

# SUBMITTAL DATA SHEET

## Hinged Saddle – 3891SB

IPS PVC x AWWA/CC



MODEL	SIZE	A	B	C	D	E	F	G
3891	2 X 3/4	3/4	2.00	2.20	1.47	HEX	2.375	1
3891	2 X 1	1	2.00	2.20	1.69	HEX	2.375	1
3891	2 1/2 X 3/4	3/4	2.00	2.56	1.69	HEX	2.875	1
3891	2 1/2 X 1	1	2.00	2.56	1.69	HEX	2.875	1
3891	3 X 3/4	3/4	2.00	2.26	1.47	HEX	3.500	1
3891	3 X 1	1	2.00	2.56	1.69	HEX	3.500	1
3891	3 X 1 1/2	1 1/2	2.50	3.72	2.82	OCT	3.500	2
3891	4 X 3/4	3/4	2.00	2.56	1.69	HEX	4.500	1
3891	4 X 1	1	2.00	2.56	1.69	HEX	4.500	1
3891	4 X 1 1/2	1 1/2	2.50	3.96	3.10	OCT	4.500	2
3891	4 X 2	2	2.50	3.96	3.10	OCT	4.500	2
3891	6 X 3/4	3/4	2.00	2.32	1.47	HEX	6.625	1
3891	6 X 1	1	2.00	2.56	1.69	HEX	6.625	1
3891	6 X 1 1/2	1 1/2	2.50	3.96	3.10	OCT	6.625	2
3891	6 X 2	2	2.50	3.96	3.10	OCT	6.625	2
3891	8 X 3/4	3/4	2.00	2.56	1.69	HEX	8.625	1
3891	8 X 1	1	2.00	2.56	1.69	HEX	8.625	1
3891	8 X 1 1/2	1 1/2	2.50	3.96	3.10	OCT	8.625	2
3891	8 X 2	2	2.50	3.96	3.10	OCT	8.625	2

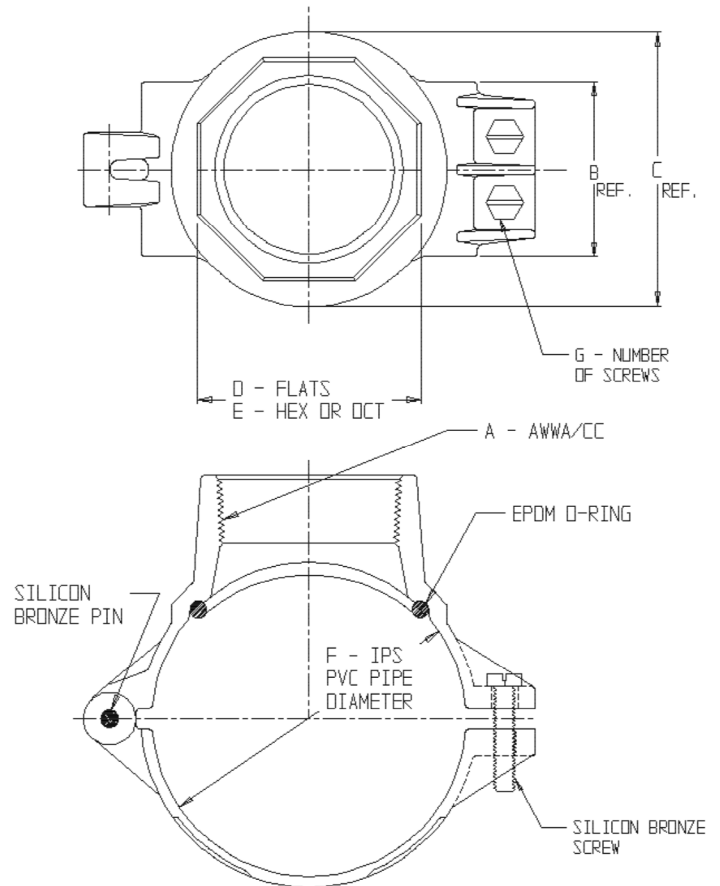

### SUBMITTAL INFORMATION

- Manufactured in compliance with ANSI/AWWA C800 (latest revision)
- Brass components conform to ASTM B62 and ASTM B584, UNS C83600 -85-5-5-5 (latest revision)
- Certified to NSF/ANSI 61
- Silicon Bronze hinge pin and bolt(s)
- EPDM o-ring
- Pipe and tap size, and thread type identified on saddle
- Outlet boss with large wrench flats



**A.Y. McDonald Mfg. CO.**  
4800 Chavenelle Rd  
Dubuque, IA 52002

**Toll Free: 1-800-292-2737**  
sales@aymcdonald.com  
[aymcdonald.com](http://aymcdonald.com)

A.Y. McDonald considers the information on this assembly drawing correct when published. Item and option availability, including specifications, are subject to change without notice.

**Submitted by:**