

SUBMITTAL DATA SHEET

Three-Wire 4" A.Y. McDonald Submersible Motors

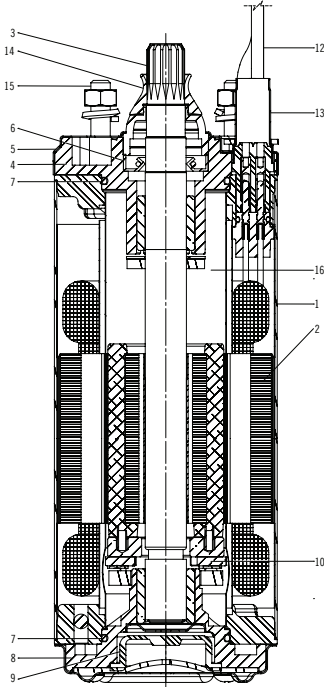

4" Asynchronous two-pole submersible motor, made in AISI 316 stainless steel for parts in contact with water. Cooling and lubrication of the thrust bearing assembly and carbon bushes is provided by a mixture of water and glycol. Squirrel-cage rotor mounted on self-centering thrust bearing. Stator housed in an airtight stainless steel casing (canned-type) with both flanges and shell in AISI 316L stainless steel. Removable cable connector to allow fast and easy maintenance. Motor suitable for use with variable frequency drive (60 Hz). For the single-phase 60 Hz version the thermal protection is included in the motor (from 1/2 HP to 1 HP). Overload protection must be provided by user for the three-phase version.



Materials

COMPONENTS		
1	Int. and external sleeve	AISI 316
2	Stator	AISI 316L / Duplex
3	Shaft end	AISI 316
4	Upper bracket	Cast Iron
5	Bracket cover	AISI 316
6	Lip seal	NBR
7	Gasket	NBR
8	Lower Bracket	Cast Iron
9	Diaphragm	EPDM
10	Thrust Bearing	Stainless Steel - Graphite
11	Valve	AISI 303
12	Cable	EPDM
13	Connecting Plug	AISI 316
14	Sand guard (fixed-removable)	NBR
15	Bolts & Screws	AISI 316
16	Cooling Liquid	Glycol + water

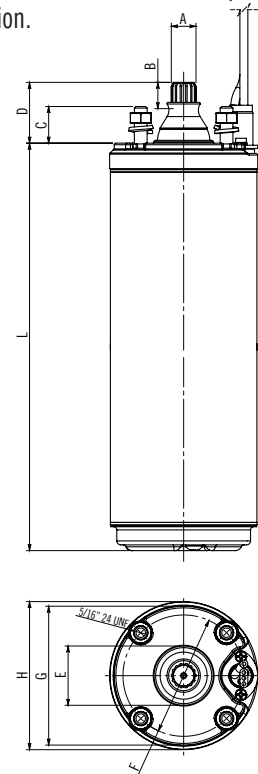

60 Hz Dimensions / Single Phase Motors

Type	L		WT	Axial Thrust	
	[HP]	[kW]			[inch]
60 Hz 3W	\diamond 1/2	0.37	10.5"	19.4	500
	\blacklozenge 1/2	0.37	11.0"	18.5	450
	3/4	0.55	11.3"	21.4	500
	1	0.75	13.6"	27.8	700
	1 1/2	1.1	16.2"	32.5	700
	2	1.5	16.2"	32.7	700
	3	2.2	21.4"	45.2	1500
	5	3.7	26.9"	59.8	1500

\diamond 1/2019 to 5/2024
 \blacklozenge 5/2024 to present

60 Hz Dimensions / Three Phase Motors

Type	L		Wt.	Axial Thrust	
	[HP]	[kW]			[inch]
60 Hz	1/2	0.37	9.3"	16.3	500
	3/4	0.55	10.5"	19.4	500
	1	0.75	11.3"	21.4	500
	1 1/2	1.1	13.6"	25.8	700
	2	1.5	15.4"	30.5	700
	3	2.2	19.8"	40.8	1500
	5	4	24.2"	51.9	1500
	7 1/2	5.5	26.9"	59.8	1500
	10	7.5	30.1"	68.7	1500

60 Hz Dimensions \diamond 1/2019 to 5/2024

Pos.	inch	Pos.	inch
A	0.61"	E	1.465"
B	0.591"	F	3"
C	0.906"	G	3.437"
D	1 1/2"	H	3.662"

60 Hz Dimensions \blacklozenge 5/2024 to present

Pos.	inch	Pos.	inch
A	0.61"	E	1.378"
B	0.59"	F	3"
C	0.88"	G	3.437"
D	1 1/2"	H	3.74"



- CSA Certified

NO-LEAD: The weighted average of the wetted surface of this no-lead product contacted by consumable water contains less than one quarter of one percent (0.25%) lead.



A.Y. McDonald Mfg. Co.
 4800 Chavenelle Rd
 Dubuque, IA 52002

Toll Free: 1-800-292-2737
 sales@aymcdonald.com
 aymcdonald.com

A.Y. McDonald considers the information on this assembly drawing correct when published. Item and option availability, including specifications, are subject to change without notice.

Submitted by:

SUBMITTAL DATA SHEET

Three-Wire

4" A.Y. McDonald Submersible Motors



Electrical Data 60 Hz

Single Phase Motors - Three-Wire

P2	V	SF	In	In (SF)	Is/In	Cs/Cn	P1	N	Cos φ	η	C1	C2	Ø	LC	
[HP]	[kW]	[V]	[A]	[A]			[W]	[min ⁻¹]		%	[uF]	[uF]	[AWG]	[ft]	
1/2	0.34	↔115	1.6	10	12.6	4.2	0.65	1050	3450	0.80	56	-	250-300	4x14	5 1/2
		◆115	1.6	11.3	14.6	4.2	0.65	1050	3450	0.80	54	-	250-300	4x14	5 1/2
		230	1.6	5.5	6.6	4.6	0.65	1130	3450	0.78	54	-	59-71	4x14	5 1/2
3/4	0.55	230	1.5	7.4	8.6	4.0	0.65	1420	3450	0.80	56	-	86-103	4x14	5 1/2
1	0.75	230	1.4	8.3	9.8	4.9	0.68	1650	3450	0.80	62	-	105-126	4x14	5 1/2
1 1/2	1.1	230	1.3	10.1	11.5	4.6	0.70	2100	3450	0.88	67	10	105-126	4x14	5 1/2
2	1.5	230	1.25	10.6	13.0	5.4	0.65	2700	3450	0.95	70	20	105-126	4x14	5 1/2
3	2.2	230	1.15	14.3	16.2	3.6	0.50	3500	3450	0.94	71	45	208-250	4x14	5 1/2
5	3.7	230	1.15	22.2	24.3	3.3	0.50	5700	3450	0.98	76	2x40	270-324	4x14	8 3/4

↔ 1/2019 to 5/2024

◆ 5/2024 to present

- P2:** Rated output
- In:** Rated current
- Cs/Cn:** Locked rotor Torque/Rated Torque
- Cos φ:** Power factor
- Ø:** Cable cross section
- V:** Rated voltage
- In (SF):** Service factor current
- P1:** Power consumption
- η:** Efficiency
- LC:** Cable length
- SF:** Service factor
- Is/In:** Locked rotor current/Rated current
- N:** R.P.M
- C:** Capacitor

Electrical Data 60 Hz

Three Phase Motors - Three-Wire

P2	V	SF	In	In (SF)	Is/In	Cs/Cn	P1	N	Cos φ	η	C	Ø	LC	
[HP]	[kW]	[V]	[A]	[A]			[W]	[min ⁻¹]		%	[uF]	[mm ²]	[ft]	
1/2	0.37	230	1.6	3.6	3.7	4.4	3.2	870	3450	0.40	42	-	4x14	5 1/2
		460	1.6	1.6	1.9	5.0	3.2	870	3450	0.40	42	-	4x14	5 1/2
3/4	0.55	230	1.5	4.6	4.9	5.2	3.6	1140	3450	0.47	48	-	4x14	5 1/2
		460	1.5	2.2	2.4	5.5	3.6	1140	3450	0.47	48	-	4x14	5 1/2
1	0.75	230	1.4	4.7	5.2	6.4	4.2	1260	3450	0.59	59	-	4x14	5 1/2
		460	1.4	2.6	2.8	5.8	4.2	1260	3450	0.59	59	-	4x14	5 1/2
1 1/2	1.1	230	1.3	8.1	8.5	5.9	4.1	1875	3450	0.53	60	-	4x14	5 1/2
		460	1.25	3.6	3.9	6.7	4.1	1875	3450	0.53	60	-	4x14	5 1/2
2	1.5	230	1.15	10.2	10.8	6.1	3.8	2230	3450	0.57	67	-	4x14	5 1/2
		460	1.15	4.6	4.9	6.7	3.8	2230	3450	0.57	67	-	4x14	5 1/2
3	2.2	230	1.15	10.7	11.6	7.5	4.8	3160	3450	0.69	71	-	4x14	5 1/2
		460	1.15	5.6	6.0	7.1	4.8	3160	3450	0.69	71	-	4x14	5 1/2
5	4	230	1.15	20.4	21.6	7.4	4.0	5230	3450	0.70	77	-	4x14	8 3/4
		460	1.15	8.9	9.6	7.4	4.0	5230	3450	0.70	77	-	4x14	8 3/4
7 1/2	5.5	230	1.15	25.7	27.5	7.5	3.8	7100	3450	0.71	78	-	4x14	8 3/4
		460	1.15	12.0	13.0	7.5	3.8	7100	3450	0.71	78	-	4x14	8 3/4
10	7.5	460	1.15	15.4	16.9	7.1	3.9	9300	3450	0.78	80	-	4x14	11 1/2

Technical Specification

Flange	NEMA 4"
Insulation class	F
Degree of protection	IP68
Cooling flow	1.0 ft/sec @ 95 °F
Voltage tolerance	+ 6% / -10%
Max starts	20/h
Max operating depth	984 ft

Components



Canned stator with external shell and flanges made in AISI 316L stainless steel. The stator has 24 slots for better elasticity and regularity of operation. Class F double insulated copper wire.



Kingsbury type thrust bearing unit consisting of tilting pads made of highly-resistant stainless steel and machined by using the spherical lapping process.



Shafts with end part made of stainless steel AISI 316/Duplex with a special process of surface hardening and polishing of the working area of the bushes. Squirrel-cage rotor made in aluminium for motor power 1/2HP through 3 HP and in copper for motor power 5 HP and above.

NO-LEAD: The weighted average of the wetted surface of this no-lead product contacted by consumable water contains less than one quarter of one percent (0.25%) lead.



A.Y. McDonald Mfg. Co.
4800 Chavenelle Rd
Dubuque, IA 52002

Toll Free: 1-800-292-2737
sales@aymcdonald.com
aymcdonald.com

A.Y. McDonald considers the information on this assembly drawing correct when published. Item and option availability, including specifications, are subject to change without notice.

Submitted by: