

# SUBMITTAL DATA SHEET

Gas Meter Bars – 6670-CCED- 1 x 1 1/4 30LT

FNPT x FNPT

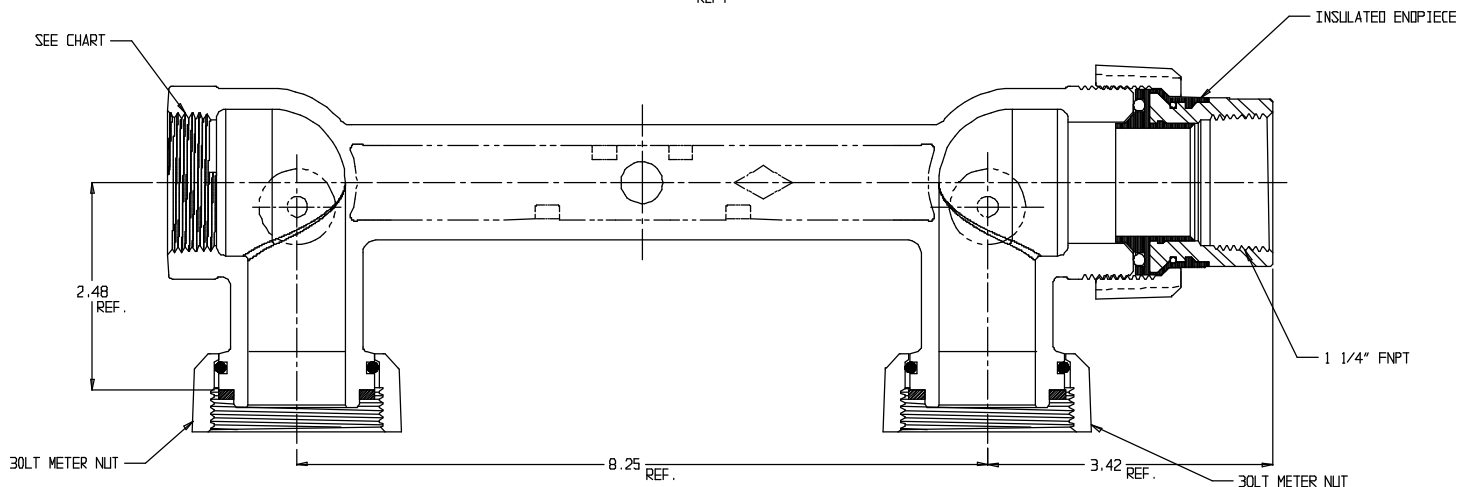
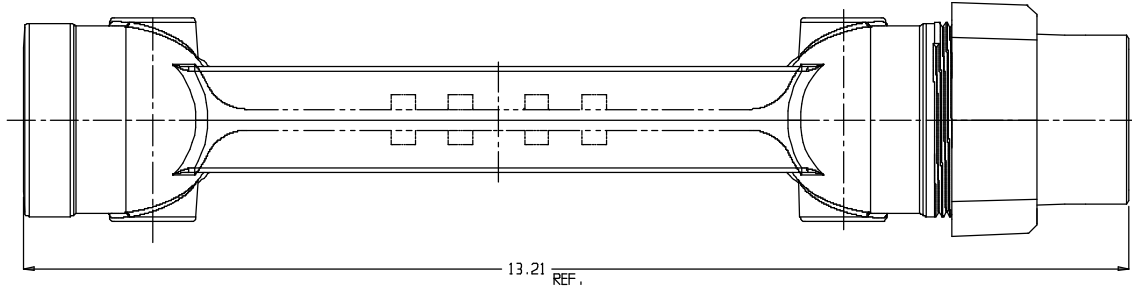

MODEL NO.	FNPT THREAD
6670-CCED- 1 X 1 1/4 30LT	1"
6670-CCED- 1 1/4 X 1 1/4 30LT	1 1/4"

## SUBMITTAL INFORMATION

- Iron meterbar castings conform to ASTM A126 Class B Iron (latest revision)
- Optional Armorgalv® coating per ASTM A1059 (latest revision)
- Pipe threads manufactured in compliance with ASME/ANSI B1.20.1 (latest revision)
- Nut castings conform to ASTM A49 or ASTM A536 (latest revision)
- Meter nuts and swivels manufactured in compliance with ANSI B109.1 (latest revision)
- Pressure test taps available in multiple positions and sizes
- Rated for 2 PSIG natural, manufactured, or LP gas pressure



**A.Y. McDonald Mfg. Co.**  
4800 Chavenelle Rd  
Dubuque, IA 52002

**Toll Free: 1-800-292-2737**  
sales@aymcdonald.com  
[aymcdonald.com](http://aymcdonald.com)

A.Y. McDonald considers the information on this assembly drawing correct when published. Item and option availability, including specifications, are subject to change without notice.

**Submitted by:**

03-22