

# SUBMITTAL DATA SHEET

NL Ball Style Corporation Stop – 73121BCAP

AWWA/CC x Increasing MNPT

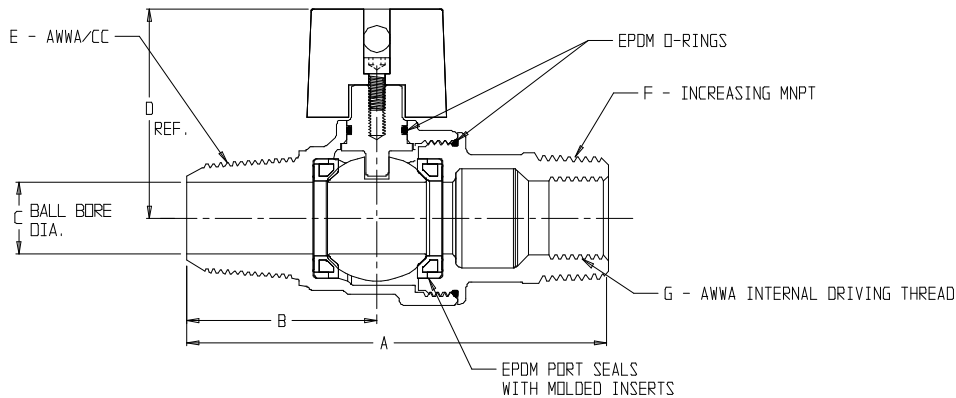
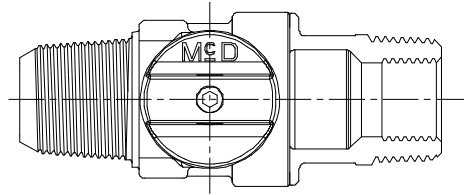

MODEL	SIZE	A	B	C	D	E	F	G
73121BCAP	3/4	4.33	1.96	.75	2.20	3/4"	1"	3/4"
73121BCAP	1	4.46	2.11	1.00	2.40	1"	1 1/4"	1"
73121BCAP	1 1/4	6.53	3.02	1.25	3.03	1 1/4"	1 1/2"	1 1/4"
73121BCAP	1 1/2	6.56	3.05	1.50	3.30	1 1/2"	2"	1 1/2"
73121BCAP	2	6.96	3.21	2.00	3.60	2"	2 1/2"	2"

## SUBMITTAL INFORMATION

- Manufactured in compliance with ANSI/AWWA C800 (latest revision)
- Brass components in contact with potable water conform to ASTM B584, UNS C89833 (latest revision) and identified with "NL"
- Certified to NSF/ANSI 61 and NSF/ANSI 372
- Brass components not in contact with potable water conform to ASTM B62 and ASTM B584, UNS C83600 -85-5-5-5 (latest revision)
- PTFE coated brass ball rotates 360°
- Valve rated for 300 PSIG water pressure, end connections not to exceed rated pipe pressures.
- Blow out proof EPDM port seals
- End piece joint sealed with an EPDM o-ring and thread locker



**A.Y. McDonald Mfg. Co.**  
4800 Chavenelle Rd  
Dubuque, IA 52002

**Toll Free: 1-800-292-2737**  
sales@aymcdonald.com  
[aymcdonald.com](http://aymcdonald.com)

A.Y. McDonald considers the information on this assembly drawing correct when published. Item and option availability, including specifications, are subject to change without notice.

**Submitted by:**