

# SUBMITTAL DATA SHEET

NL Ball Style Corporation Stop – 73122B

MNPT x Increasing MNPT

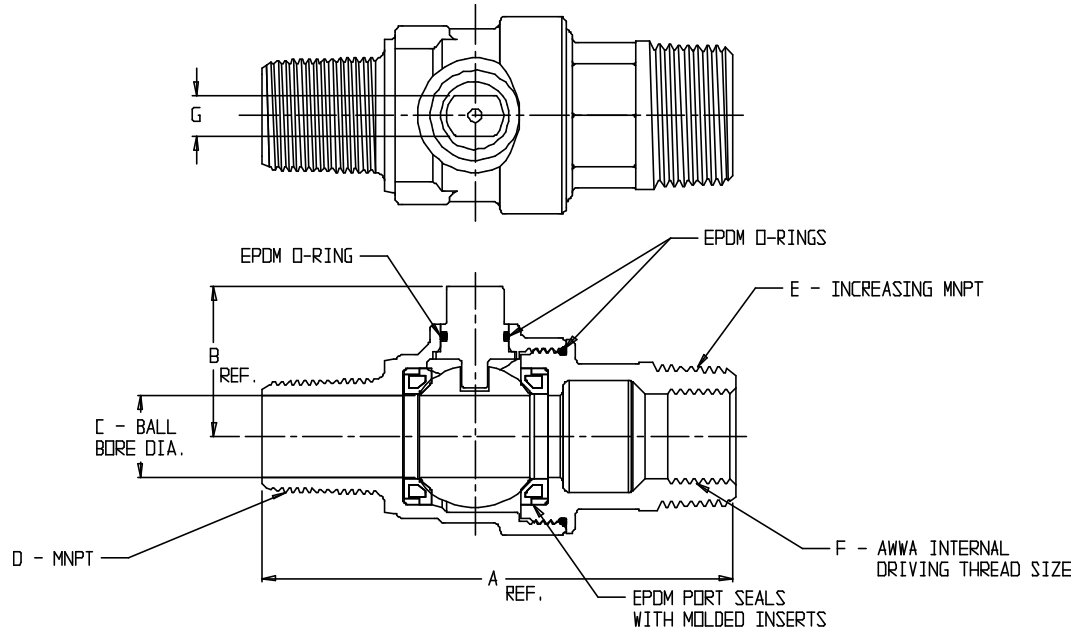

MODEL	SIZE	A	B	C	D	E	F	G
73122B	3/4	4.33	1.39	.75	3/4	1	3/4	.38
73122B	1	4.63	1.50	1.00	1	1 1/4	1	.28
73122B	1 1/4	6.53	1.88	1.25	1 1/4	1 1/2	1 1/4	.42
73122B	1 1/2	6.57	2.15	1.50	1 1/2	2	1 1/2	.42
73122B	2	6.96	2.45	2.00	2	2 1/2	2	.42

## SUBMITTAL INFORMATION

- Manufactured in compliance with ANSI/AWWA C800 (latest revision)
- Brass components in contact with potable water conform to ASTM B584, UNS C89833 (latest revision) and identified with “NL”
- Certified to NSF/ANSI 61 and NSF/ANSI 372
- Brass components not in contact with potable water conform to ASTM B62 and ASTM B584, UNS C83600 -85-5-5-5 (latest revision)
- PTFE coated brass ball rotates 360°
- Valve rated for 300 PSIG water pressure, end connections not to exceed rated pipe pressures.
- Blow out proof EPDM port seals
- End piece joint sealed with an EPDM o-ring and thread locker



**A.Y. McDonald Mfg. Co.**  
4800 Chavenelle Rd  
Dubuque, IA 52002

**Toll Free: 1-800-292-2737**  
sales@aymcdonald.com  
[aymcdonald.com](http://aymcdonald.com)

A.Y. McDonald considers the information on this assembly drawing correct when published. Item and option availability, including specifications, are subject to change without notice.

**Submitted by:**