

SUBMITTAL DATA SHEET

NL Ball Style Corporation Stop – 74101B-33

AWWA/CC x -33 PEP Compression

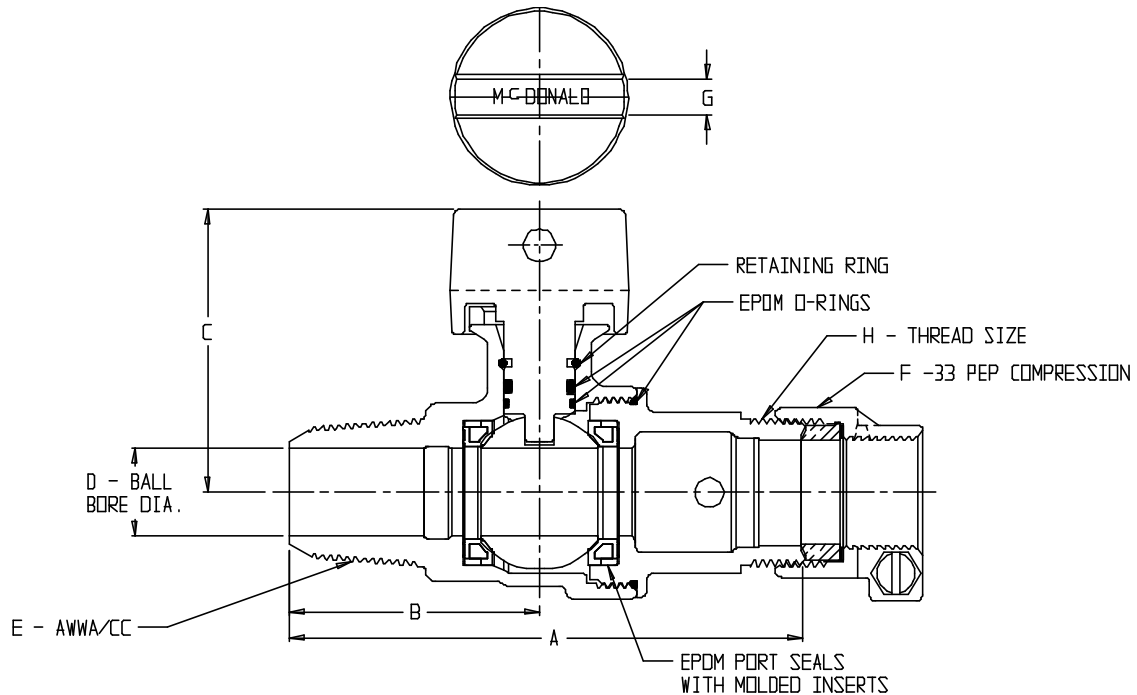

| MODEL | SIZE | A | B | C | D | E | F | G | H |
|-----------|------|------|------|------|------|-----|-----|-----|------------------|
| 74101B-33 | 3/4 | 4.62 | 2.14 | 2.42 | .75 | 3/4 | 3/4 | .30 | 1 AWWA FLARE |
| 74101B-33 | 1 | 5.07 | 2.59 | 2.65 | 1.00 | 1 | 1 | .30 | 1 1/4 AWWA FLARE |
| 74101B-33 | 2 | 8.80 | 4.32 | 3.70 | 2.00 | 2 | 2 | .3B | 2 AWWA FLARE |

SUBMITTAL INFORMATION

- Manufactured in compliance with ANSI/AWWA C800 (latest revision)
- Brass components in contact with potable water conform to ASTM B584, UNS C89833 (latest revision) and identified with “NL”
- Certified to NSF/ANSI 61 and NSF/ANSI 372
- Brass components not in contact with potable water conform to ASTM B62 and ASTM B584, UNS C83600 -85-5-5-5 (latest revision)
- PTFE coated brass ball rotates 90°
- Valve rated for 300 PSIG water pressure, end connections not to exceed rated pipe pressure.
- Blow out proof EPDM port seals
- End piece joint sealed with an EPDM o-ring and thread locker
- Insert stiffeners required on all flexible plastic connections



A.Y. McDonald Mfg. Co.
4800 Chavenelle Rd
Dubuque, IA 52002

Toll Free: 1-800-292-2737
sales@aymcdonald.com
aymcdonald.com

A.Y. McDonald considers the information on this assembly drawing correct when published. Item and option availability, including specifications, are subject to change without notice.

Submitted by: