

# SUBMITTAL DATA SHEET

NL Ball Style Corporation Stop – 74104BT

MNPT x T CTS Compression

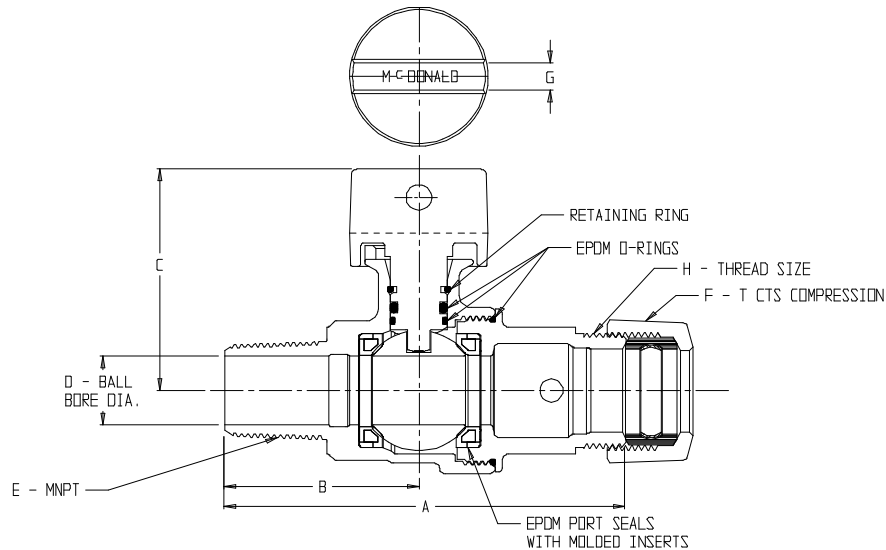

MODEL	SIZE	A	B	C	D	E	F	G	H
74104BT	3/4	4.39	2.14	2.42	.75	3/4	3/4	.30	3/4 AWWA FLARE
74104BT	1	4.97	2.59	2.65	1.00	1	1	.30	1 AWWA FLARE
74104BT	1 1/2	6.43	3.05	3.40	1.50	1 1/2	1 1/2	.40	2 1/8 - 16 SPECIAL
74104BT	2	7.64	3.96	3.71	2.00	2	2	.40	2 5/8 - 16 SPECIAL
74104BTFT	1 1/2	6.08	3.05	3.40	1.50	1 1/2	1 1/2	.40	1 1/2 AWWA FLARE
74104BTFT	2	8.28	3.96	3.71	2.00	2	2	.40	2 AWWA FLARE

## SUBMITTAL INFORMATION

- Manufactured in compliance with ANSI/AWWA C800 (latest revision)
- Brass components in contact with potable water conform to ASTM B584, UNS C89833 (latest revision) and identified with “NL”
- Certified to NSF/ANSI 61 and NSF/ANSI 372
- Brass components not in contact with potable water conform to ASTM B62 and ASTM B584, UNS C83600 -85-5-5-5 (latest revision)
- PTFE coated brass ball rotates 90°
- Valve rated for 300 PSIG water pressure, end connections not to exceed rated pipe pressure.
- Blow out proof EPDM port seals
- End piece joint sealed with an EPDM o-ring and thread locker
- Insert stiffeners required on all flexible plastic connections



**A.Y. McDonald Mfg. Co.**  
4800 Chavenelle Rd  
Dubuque, IA 52002

**Toll Free: 1-800-292-2737**  
sales@aymcdonald.com  
[aymcdonald.com](http://aymcdonald.com)

A.Y. McDonald considers the information on this assembly drawing correct when published. Item and option availability, including specifications, are subject to change without notice.

**Submitted by:**