

SUBMITTAL DATA SHEET

NL Ball Style Corporation Stop – 74704BGFT

MNPT x G CTS Compression

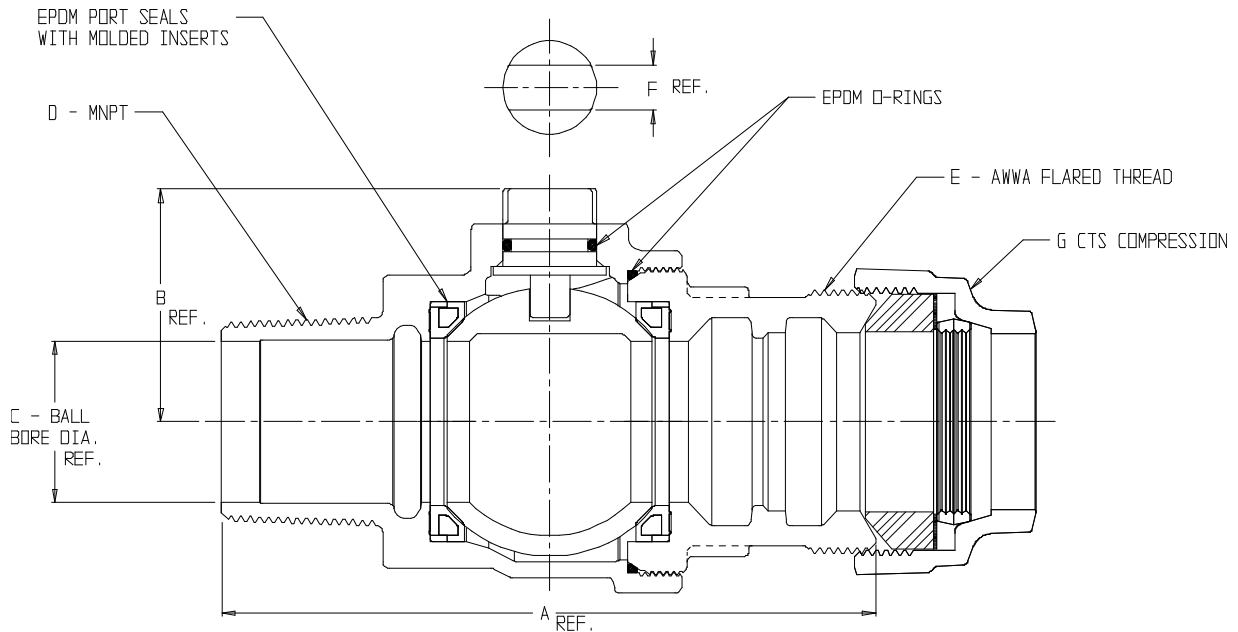

MODEL NO.	SIZE	A	B	C	D	E	F
74704BGFT	1 1/2	6.08	2.15	1.50	1 1/2"	1 1/2"	.42
74704BGFT	1 1/2 X 2	6.96	2.15	1.50	1 1/2"	2"	.42
74704BGFT	2	7.53	2.46	2.00	2"	2"	.42

SUBMITTAL INFORMATION

- Manufactured in compliance with ANSI/AWWA C800 (latest revision)
- Brass components in contact with potable water conform to ASTM B584, UNS C89833 (latest revision) and identified with "NL"
- Certified to NSF/ANSI 61 and NSF/ANSI 372
- Brass components not in contact with potable water conform to ASTM B62 and ASTM B584, UNS C83600 -85-5-5-5 (latest revision)
- PTFE coated brass ball rotates 360°
- Valve rated for 300 PSIG water pressure, end connections not to exceed rated pipe pressures.
- Blow out proof EPDM port seals
- End piece joint sealed with an EPDM o-ring and thread locker
- Insert stiffener required on all flexible plastic connections



A.Y. McDonald Mfg. Co.
4800 Chavenelle Rd
Dubuque, IA 52002

Toll Free: 1-800-292-2737
sales@aymcdonald.com
aymcdonald.com

A.Y. McDonald considers the information on this assembly drawing correct when published. Item and option availability, including specifications, are subject to change without notice.

Submitted by: