

# SUBMITTAL DATA SHEET

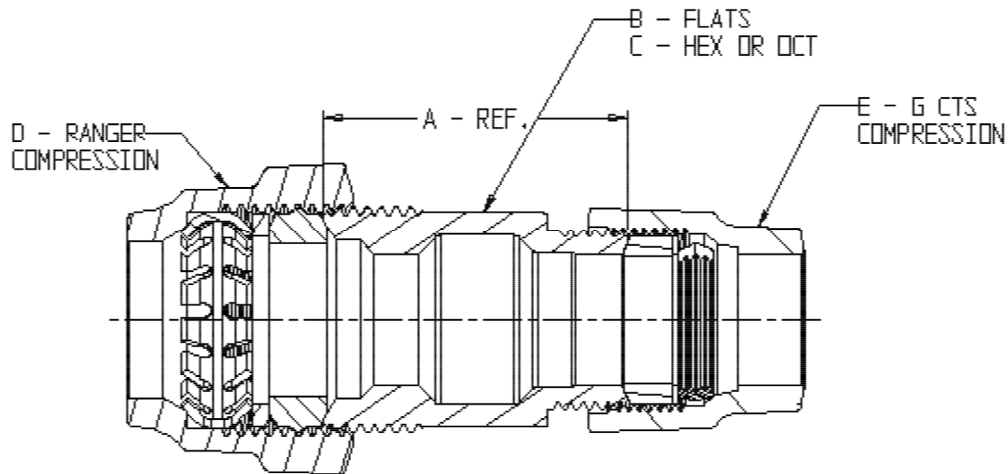

NL Service Fitting – 74758G-11

-11 Ranger Compression x G CTS Compression



MODEL NO.	SIZE	A	B	C	D	PIPE/TUBE SIZE RANGE (IN.)	E
74758G-11	3/4	2.11	1.38	OCT	3/4	.871-1.089	3/4
74758G-11	1	2.28	1.57	OCT	1	1.120-1.399	1

NOTE: McDONALD RANGER NUTS ARE NOT COMPATIBLE WITH OTHER MANUFACTURERS COMPRESSION NUT SYSTEMS.  
 McDONALD RANGER NUTS ARE NOT COMPATIBLE WITH OTHER McDONALD COMPRESSION NUT SYSTEMS

## SUBMITTAL INFORMATION

- Manufactured in compliance with ANSI/AWWA C800 (latest revision)
- Brass components in contact with potable water conform to ASTM B584, UNS C89833 (latest revision) and identified with “NL”
- Certified to NSF/ANSI 61 and NSF/ANSI 372
- Brass components not in contact with potable water conform to ASTM B62 and ASTM B584, UNS C83600 -85-5-5-5 (latest revision)
- Large wrench flats provided for proper installation
- Insert stiffeners required on all flexible plastic connections



A.Y. McDonald Mfg. Co.  
 4800 Chavenelle Rd  
 Dubuque, IA 52002

Toll Free: 1-800-292-2737  
 sales@aymcdonald.com  
[aymcdonald.com](http://aymcdonald.com)

A.Y. McDonald considers the information on this assembly drawing correct when published. Item and option availability, including specifications, are subject to change without notice.

Submitted by: