

# SUBMITTAL DATA SHEET

## NL Stop and Waste Ball Curb Stop – 76000Q

Q CTS Compression x Q CTS Compression

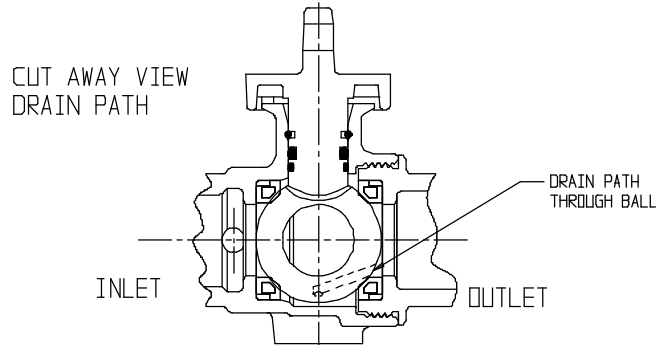

MODEL	SIZE	A	B	C	D	E
76000Q	3/4	4.00	2.42	3/4	3/4	3/4
76000Q	1	4.47	2.65	1	1	1
76000Q	1 1/2	6.05	3.40	1 1/2	1 1/2	1 1/2
76000Q	2	6.99	3.71	2	2	2

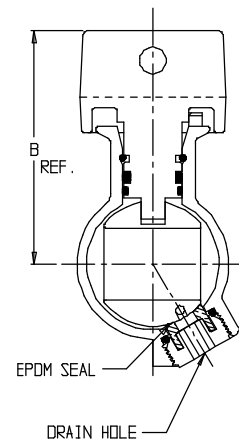
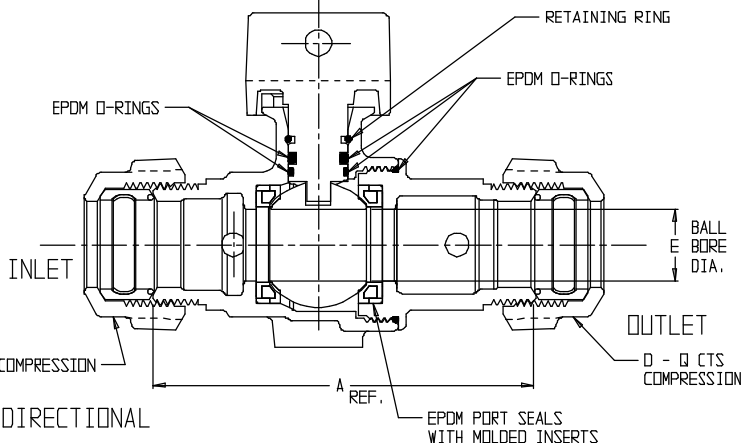

NOTE: VALVES ARE DIRECTIONAL

### SUBMITTAL INFORMATION

- Manufactured in compliance with ANSI/AWWA C800 (latest revision)
- Brass components in contact with potable water conform to ASTM B584, UNS C89833 (latest revision) and identified with "NL"
- Certified to NSF/ANSI 61 and NSF/ANSI 372
- Brass components not in contact with potable water conform to ASTM B62 and ASTM B584, UNS C83600 -85-5-5-5 (latest revision)
- PTFE coated brass ball
- Rated for 150 PSIG water pressure with cast directional arrow
- Blow out proof EPDM port seals
- Joints sealed with EPDM o-rings and thread locker
- Insert stiffeners required on all flexible plastic connections



**A.Y. McDonald Mfg. CO.**  
4800 Chavenelle Rd  
Dubuque, IA 52002

**Toll Free: 1-800-292-2737**  
sales@aymcdonald.com  
[aymcdonald.com](http://aymcdonald.com)

A.Y. McDonald considers the information on this assembly drawing correct when published. Item and option availability, including specifications, are subject to change without notice.

**Submitted by:**