

SUBMITTAL DATA SHEET

Snap Clamps – 428UDL

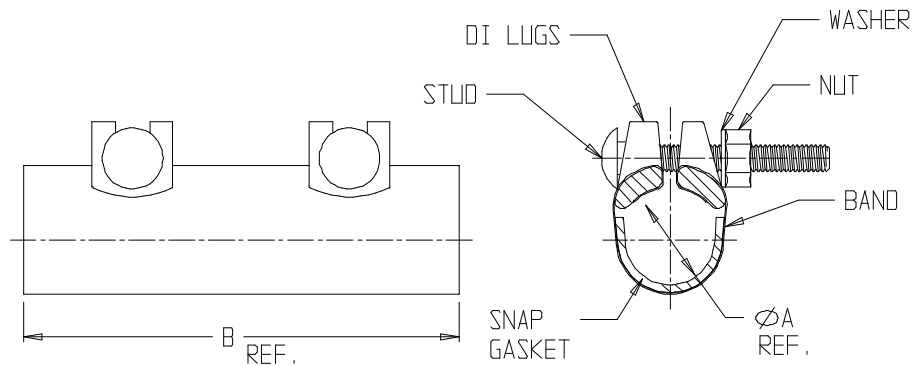

WIDTH	# OF BOLTS
3"	1
6"	2
9"	3
12"	4

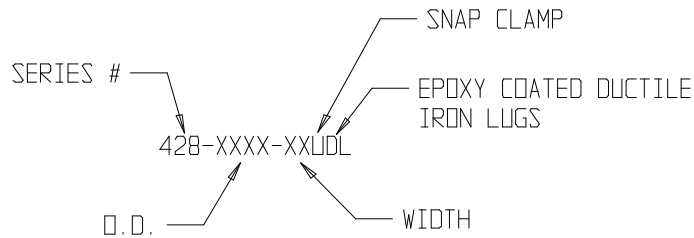

PIPE SIZE	A - O.D.	MODEL #	B - WIDTHS
1/2" IPS	0.840	428-0084-XXUDL	3", 6"
3/4" IPS	1.050	428-0105-XXUDL	3", 6", 9"
1" IPS	1.315	428-0132-XXUDL	3", 6", 9"
1 1/4" IPS	1.660	428-0166-XXUDL	3", 6", 9"
1 1/2" IPS	1.900	428-0190-XXUDL	3", 6", 9", 12"
2" IPS	2.375	428-0238-XXUDL	3", 6", 9", 12"
2 1/2" IPS	2.875	428-0288-XXUDL	3", 6", 9", 12"

SUBMITTAL INFORMATION

- Band – 18-8 Type 304 Stainless Steel
- Lug – Epoxy Coated Ductile Iron
- Gasket – Nitrile
- Studs – Carbon Steel Electro Galvanized with Di-Chromate Seal
- Nuts – Carbon Steel Electro Galvanized with Di-Chromate Seal
- Washers - Carbon Steel Electro Galvanized with Di-Chromate Seal



A.Y. McDonald Mfg. Co.
4800 Chavenelle Rd
Dubuque, IA 52002

Toll Free: 1-800-292-2737
sales@aymcdonald.com
aymcdonald.com

A.Y. McDonald considers the information on this assembly drawing correct when published. Item and option availability, including specifications, are subject to change without notice.

Submitted by: