

SUBMITTAL DATA SHEET

Stainless Steel Repair Clamp – 435T

4" – 12" Diameters 3/4" – 2" Taps

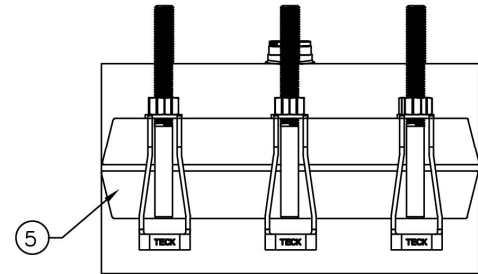
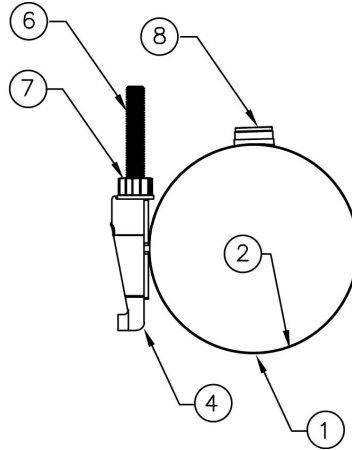
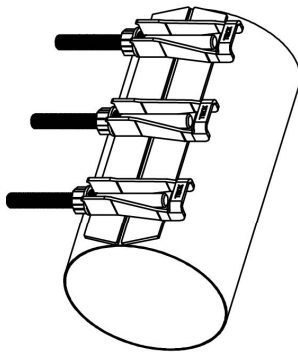

PARTS AND MATERIAL

- | | |
|--------------------|--|
| 1. Band: | 304 Stainless Steel
Available widths 8", 12", 16", 20", 24"
Available diameters, 4" to 12", nominal sizes, custom sizes available. |
| 2. Gasket: | Grid gaskets with taper joints are made from Nitrile meets ASTM D2000 & NSF 61 |
| 3. Lifter Plate: | 18-8 type 304 Stainless Steel |
| 4. Finger Bracket: | 18-8 type 304 Stainless Steel |
| 5. Side Bar: | 18-8 type 304 Stainless Steel |
| 6. Studs: | Stainless Steel 5/8" roll NC thread |
| 7. Nuts: | 5/8-11 Stainless Steel heavy hex nuts coated to prevent galling |
| 8. Stainless Taps: | 304 Stainless Steel, welded SS outlet. |

SUBMITTAL INFORMATION

- All components are made of SS304 type stainless steel.
- Fully Passivated for corrosion resistance.
- TECK finger design – no loose parts for assembly.
- Repair Clamp size laser etched on each repair clamp.
- 0.4" pipe diameter range.
- Grid gasket with taper joint
- Rated for 150 PSI working pressure
- Fluoropolymer coated nuts to prevent galling.
- Recommended bolt torque - 60 ft. lbs.
- Contact factory for additional options.



A.Y. McDonald Mfg. Co.
4800 Chavenelle Rd
Dubuque, IA 52002

Toll Free: 1-800-292-2737
sales@aymcdonald.com
aymcdonald.com

A.Y. McDonald considers the information on this assembly drawing correct when published. Item and option availability, including specifications, are subject to change without notice.

Submitted by:

04-16