

# SUBMITTAL DATA SHEET

## Snap Clamps – 428USL

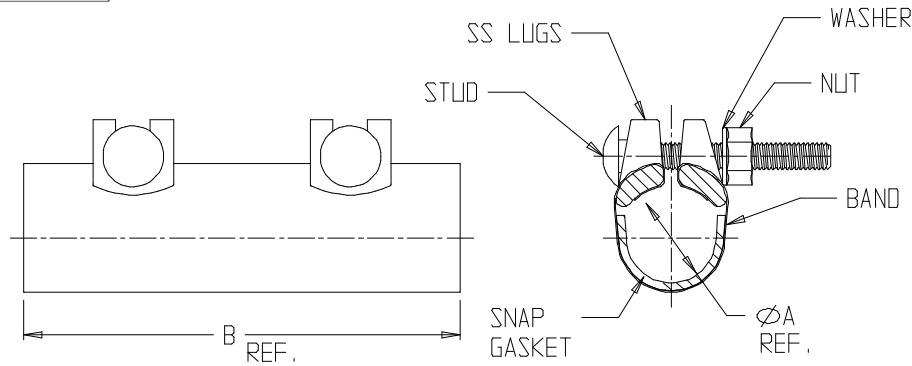

WIDTH	# OF BOLTS
3"	1
6"	2
9"	3
12"	4

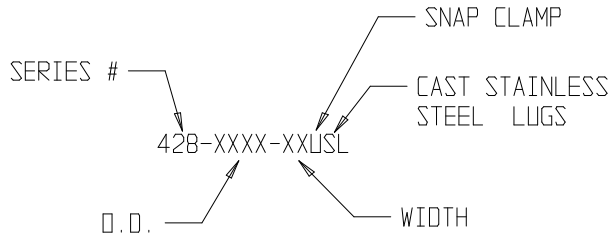

PIPE SIZE	A - O.D.	MODEL #	B - WIDTHS
1/2" IPS	0.840	428-0084-XXUSL	3", 6"
3/4" IPS	1.050	428-0105-XXUSL	3", 6", 9"
1" IPS	1.315	428-0132-XXUSL	3", 6", 9"
1 1/4" IPS	1.660	428-0166-XXUSL	3", 6", 9"
1 1/2" IPS	1.900	428-0190-XXUSL	3", 6", 9", 12"
2" IPS	2.375	428-0238-XXUSL	3", 6", 9", 12"
2 1/2" IPS	2.875	428-0288-XXUSL	3", 6", 9", 12"

### SUBMITTAL INFORMATION

- Band – 18-8 Type 304 Stainless Steel
- Lug – Type 304 Cast Stainless Steel
- Gasket – Nitrile
- Studs – Type 304 Stainless Steel Grade 8
- Nuts – Type 304 Stainless Steel Grade 8
- Washers – Type 304 Stainless Steel



A.Y. McDonald Mfg. Co.  
4800 Chavenelle Rd  
Dubuque, IA 52002

Toll Free: 1-800-292-2737  
sales@aymcdonald.com  
[aymcdonald.com](http://aymcdonald.com)

A.Y. McDonald considers the information on this assembly drawing correct when published. Item and option availability, including specifications, are subject to change without notice.

Submitted by: