

SUBMITTAL DATA SHEET

Service Fitting – 4700G

G CTS Compression Nut

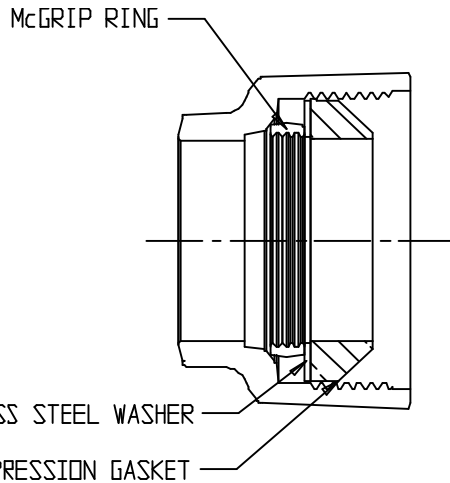

MODEL	SIZE
4700G	3/4
4700G	1
4700G	1 1/4
4700G-12	1 1/2
4700G-12	2

CORP USE	
MODEL	SIZE
4700GFT	1 1/2
4700G-16	1 1/2
4700GFT	2
4700G-16	2

NOTE: McDONALD GRIP NUTS ARE NOT COMPATIBLE WITH OTHER MANUFACTURERS COMPRESSION NUT SYSTEMS

SUBMITTAL INFORMATION

- Manufactured in compliance with ANSI/AWWA C800 (latest revision)
- Brass components conform to ASTM B62 and ASTM B584, UNS C83600 -85-5-5-5 (latest revision)
- Large wrench flats provided for proper installation



A.Y. McDonald Mfg. Co.
4800 Chavenelle Rd
Dubuque, IA 52002

Toll Free: 1-800-292-2737
sales@aymcdonald.com
aymcdonald.com

A.Y. McDonald considers the information on this assembly drawing correct when published. Item and option availability, including specifications, are subject to change without notice.

Submitted by: