

SUBMITTAL DATA SHEET

Sump, Sewage, & Effluent Pumps
DuraMAC™ | Guardian

5020PUUP Utility Pump



See Pumps & Accessories
Price List for Limited
Warranty details.

This 5020PUUP can handle up to 26 gallons per minute (GPM). Built with a tough thermoplastic construction, it has a sleek design that allows the pump to fit in a 6" or larger opening.

Performance Curve

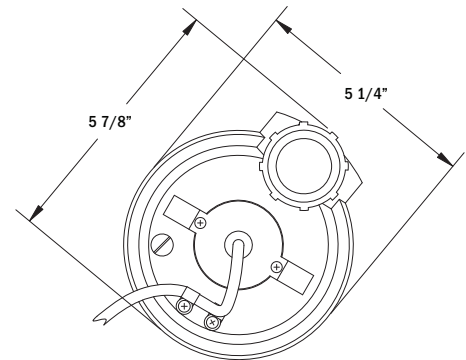
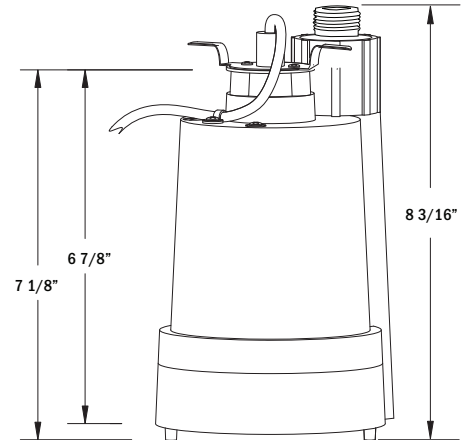
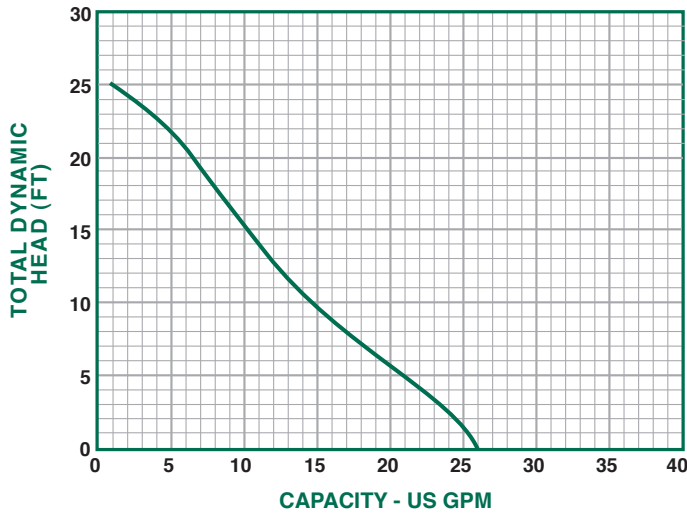

Performance

Model	Gallons per Minute in Feet					
	0	5	10	15	20	25
5020PUUP	26	21	14	10	7	1

Specifications

Part No.	Model No.	HP	Volts	Hz	Amps	Construction	Discharge Size	Cord Length	Solids Handling	RPM	Phase	Wt.
6190-145	5020PUUP	1/5	120	60	3.6	Thermoplastic	1 1/4"	10'	1/8"	3450	1	8

SUBMITTAL INFORMATION

- Split Capacitor Motor - 1/5 HP continuous duty, thermal protected
- Lifts water up to 25' of vertical height
- 10' Power Cord
- 3/4" Garden hose adapter included
- Large 1 1/4" discharge for high capacity pumping
- Clog resistant impeller



NO-LEAD: The weighted average of the wetted surface of this no-lead product contacted by consumable water contains less than one quarter of one percent (0.25%) lead.



A.Y. McDonald Mfg. Co.
4800 Chavenelle Rd
Dubuque, IA 52002

Toll Free: 1-800-292-2737
sales@aymcdonald.com
aymcdonald.com

A.Y. McDonald considers the information on this assembly drawing correct when published. Item and option availability, including specifications, are subject to change without notice.

Submitted by: