

SUBMITTAL DATA SHEET

NL Ball Style Curb Stop – 76100REPQ-11

-11 Ranger Compression X Q CTS Compression

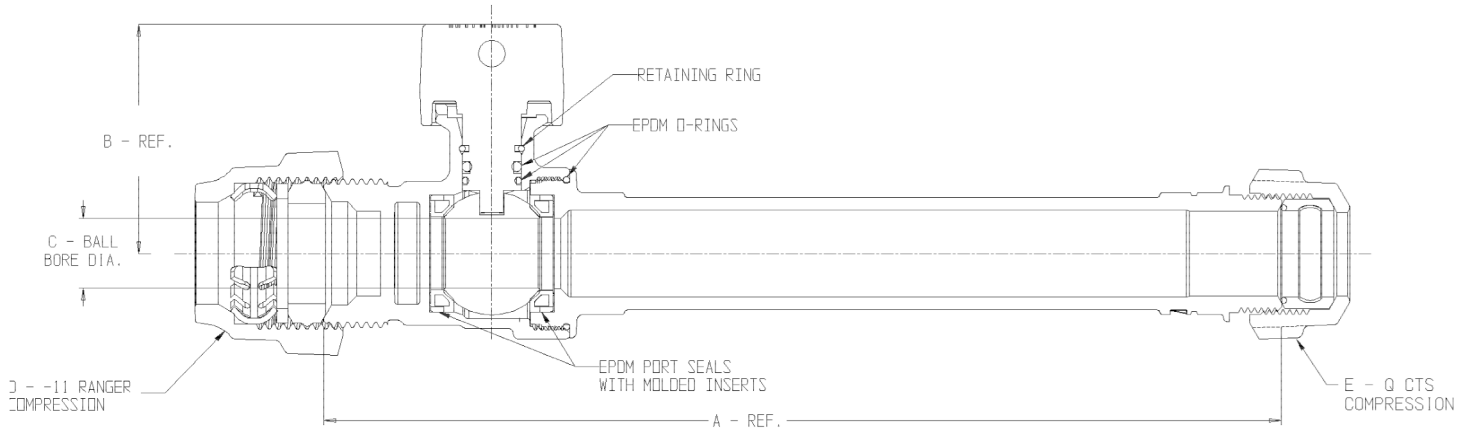

MODEL	SIZE	A	B	C	D	- 11 END PIPE/TUBE SIZE RANGE (in)	E
76100REPQ-11	3/4 X 10.12	10.16	2.43	.75	3/4	.871-1.089	3/4
76100REPQ-11	1 X 10.50	10.50	2.64	1.00	1	1.120-1.399	1

NOTE: McDONALD RANGER NUTS ARE NOT COMPATIBLE WITH OTHER MANUFACTURERS COMPRESSION NUT SYSTEMS
 McDONALD RANGER NUTS ARE NOT COMPATIBLE WITH OTHER McDONALD COMPRESSION NUT SYSTEMS

SUBMITTAL INFORMATION

- Manufactured in compliance with ANSI/AWWA C800 (latest revision)
- Brass components in contact with potable water conform to ASTM B584, UNS C89833 (latest revision) and identified with "NL"
- Certified to NSF/ANSI 61 and NSF/ANSI 372
- Brass components not in contact with potable water conform to ASTM B62 and ASTM B584, UNS C83600 -85-5-5-5 (latest revision)
- PTFE coated brass ball
- Valve rated for 300 PSIG water pressure, end connections not to exceed rated pipe pressures.
- Blow out proof EPDM port seals
- End piece joint sealed with an EPDM O-ring and thread locker
- Insert stiffeners required on all flexible plastic connections



A.Y. McDonald Mfg. Co.
 4800 Chavenelle Rd
 Dubuque, IA 52002

Toll Free: 1-800-292-2737
sales@aymcdonald.com
aymcdonald.com

A.Y. McDonald considers the information on this assembly drawing correct when published. Item and option availability, including specifications, are subject to change without notice.

Submitted by: