

SUBMITTAL DATA SHEET

No-Lead
Angle Sillcock with Wide Flange – 72014EXPWF

Expansion Pex x MGHT

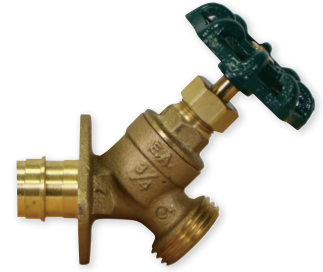

A.Y. McDonald Mfg. Co. angle sillcock are ideal for applications that require the use of a quality low pressure hose valve. The wide flange allows for easier access to the mounting holes and better installation.

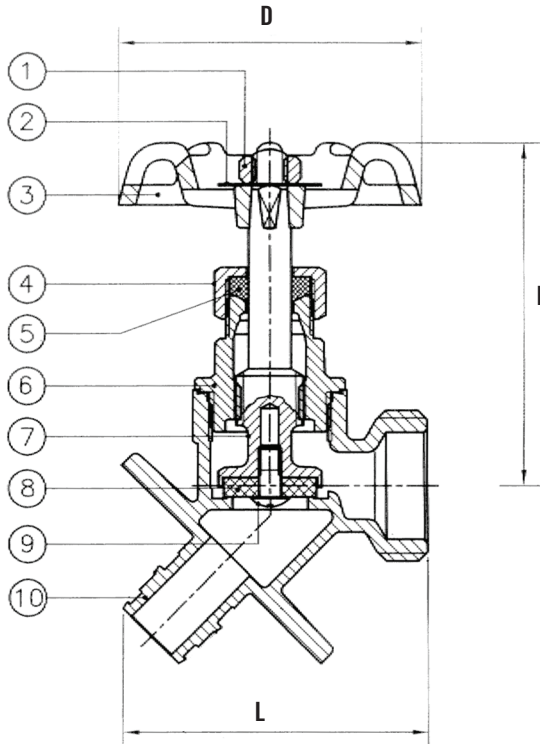

Materials

No.	Parts	Materials	No.	Parts	Materials
1	Wheel Nut	Hot Rolled Steel	6	Bonnet	No-Lead Brass
2	Name Plate	Aluminim	7	Stem	No-Lead Brass
3	Handle	Cast Iron	8	Seat Packing	Rubber (NBR)
4	Packing Nut	Brass Rod	9	Screw	Forged Brass C26000
5	Packing	Rubber (NBR)	10	Body	No-Lead Brass

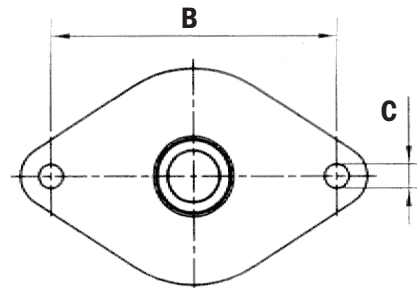

Dimensions

Part No.	Model No.	Description	B	C	D	H	L
5423-449	72014EXPWF	1/2" Expansion Pex x 3/4" MGHT	2.58	0.22	2.09	2.40	2.13
5423-450	72014EXPWF	3/4" Expansion Pex x 3/4" MGHT	2.58	0.22	2.09	2.40	2.40

SUBMITTAL INFORMATION

- Available Sizes: 1/2" and 3/4"
- 125 WOG
- NSF/ANSI 372
- NSF/ANSI 61
- Pex end conforms to ASTM F1960



NO-LEAD: The weighted average of the wetted surface of this no-lead product contacted by consumable water contains less than one quarter of one percent (0.25%) lead.



A.Y. McDonald Mfg. Co.
P.O. Box 508
Dubuque, IA 52004-0508

Toll Free: 1-800-292-2737
Fax: 1-800-832-9296
Hours: 7:00 a.m. - 5:00 p.m., CST

sales@aymcdonald.com
www.aymcdonald.com

A.Y. McDonald considers the information on this assembly drawing correct when published. Item and option availability, including specifications, are subject to change without notice.

Submitted by: