

SUBMITTAL DATA SHEET

No-Lead
Dielectric Unions – 72110FFB

FNPT x FNPT

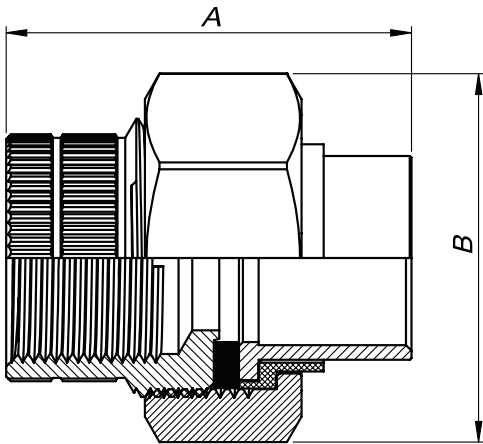
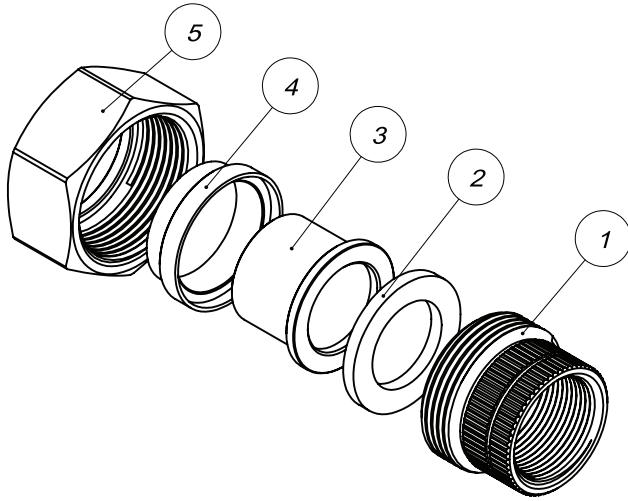
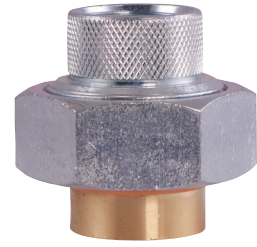

Materials

No.	Part	Material
1	Body	Forged carbon steel, galvanized
2	Washer	EPDM & NBR
3	Body	No-Lead Brass
4	Insulator Sleeve	Nylon
5	Nut	Forged carbon steel, galvanized

Dimensions

Part No.	Model No.	Size	A	B
5427-144	72110FFB	1/2"	1.8"	1.6"
5427-145	72110FFB	3/4"	2.0"	2.3"
5427-146	72110FFB	1"	2.3"	2.8"

SUBMITTAL INFORMATION

- Steel FNPT x Brass FNPT
- 200 PSI at 180°F
- For use whenever dissimilar metals are used in a piping system to prevent deterioration from corrosion due to stray currents
- For repair gaskets order 2110R

NO-LEAD: The weighted average of the wetted surface of this no-lead product contacted by consumable water contains less than one quarter of one percent (0.25%) lead.



A.Y. McDonald Mfg. Co.
4800 Chavenelle Rd
Dubuque, IA 52002

Toll Free: 1-800-292-2737
sales@aymcdonald.com
aymcdonald.com

A.Y. McDonald considers the information on this assembly drawing correct when published. Item and option availability, including specifications, are subject to change without notice.

Submitted by: