

# SUBMITTAL DATA SHEET

## X-RISER XR-27G-20-36-ZDC

PE Tube Size: 1 1/4" IPS (SDR 11/.151" Wall)

Outlet: 1 1/4" MNPT

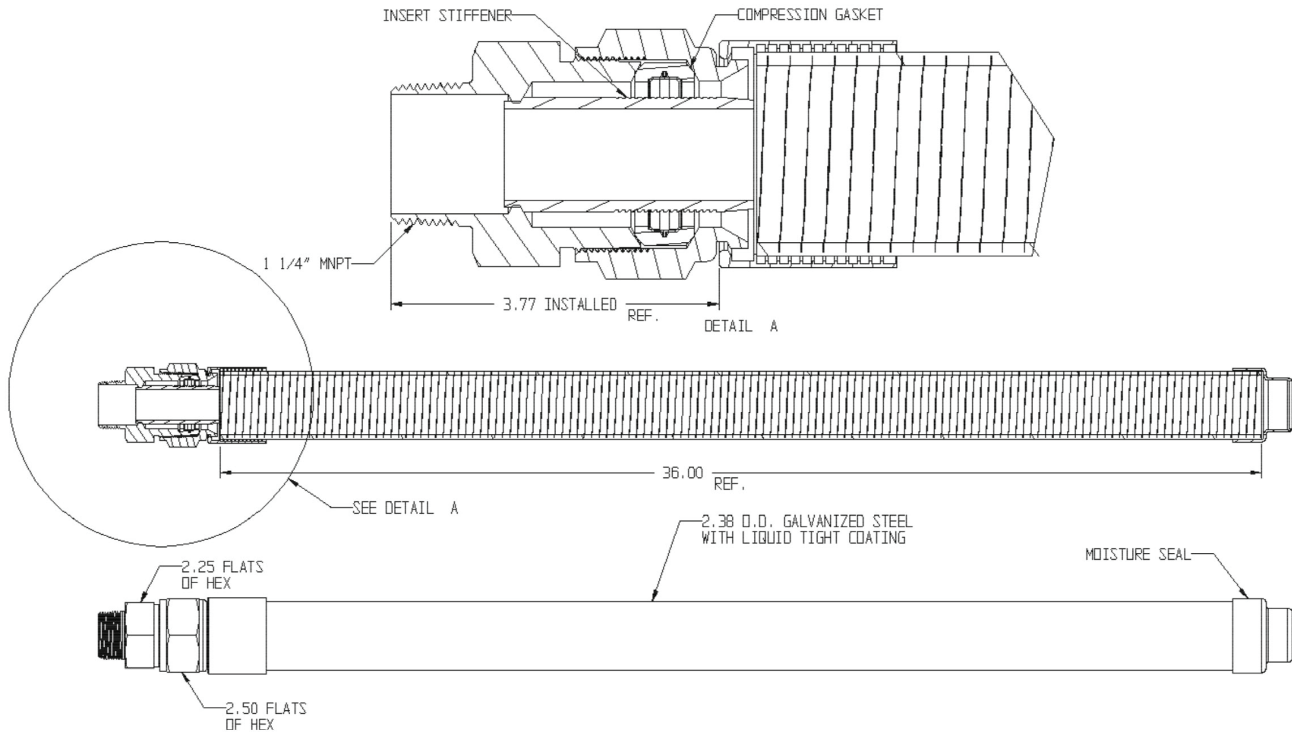

### SUBMITTAL INFORMATION

- Bodies, Nuts and Stiffeners made of C12L14 Steel
- 70 Durometer Buna-N Seals
- Ferrules made of C1050 Steel
- Gray E Coating per ASTM D870, ASTM D1735, ASTM D2794, ASTM D3363
- ZDC = Yellow Trivalent Zinc Plating per ASTM B633 VI
- Meets all applicable requirements defined under 49CFR Part 192, D.O.T. 192.281, 192.283(b), 192.375, ASTM D2513 Category 1, ASTM F1973, ASTM F1948-12 Category 1, NFPA 58, NFPA 54 (ANSI Z223.1) and IFGC Section 403. IAPMO/UPC/IPC/CSA Listed.



**Chicago Fittings**  
3170 E Colley Road  
Beloit, WI 53511

**Toll Free:** 1-877-638-9009  
**Fax:** 1-608-299-8901  
**Hours:** 7:30 a.m. – 4:30 p.m., CST

info@chicagofittngs.com  
chicagofittings.com

Chicago Fittings considers the information on this assembly drawing correct when published. Item and option availability, including specifications, are subject to change without notice.

**Submitted by:**